

Wap

CATÁLOGO DE PEÇAS PARA REPOSIÇÃO



ASPIRADOR DE ÁGUA E PÓ GTW 10

FW005705 (127V)
FW005706 (220V)

REVISÃO: 05 - SETEMBRO/2024
REFERÊNCIA: VEG02.013

Vista Explodida

OBSERVAÇÃO

Para produtos com letra A em seu numero de serie
 FW005705AXXXXXYY2022
 FW005706AXXXXXYY2022
 O filtro utilizado é item 30 (Fw008889)

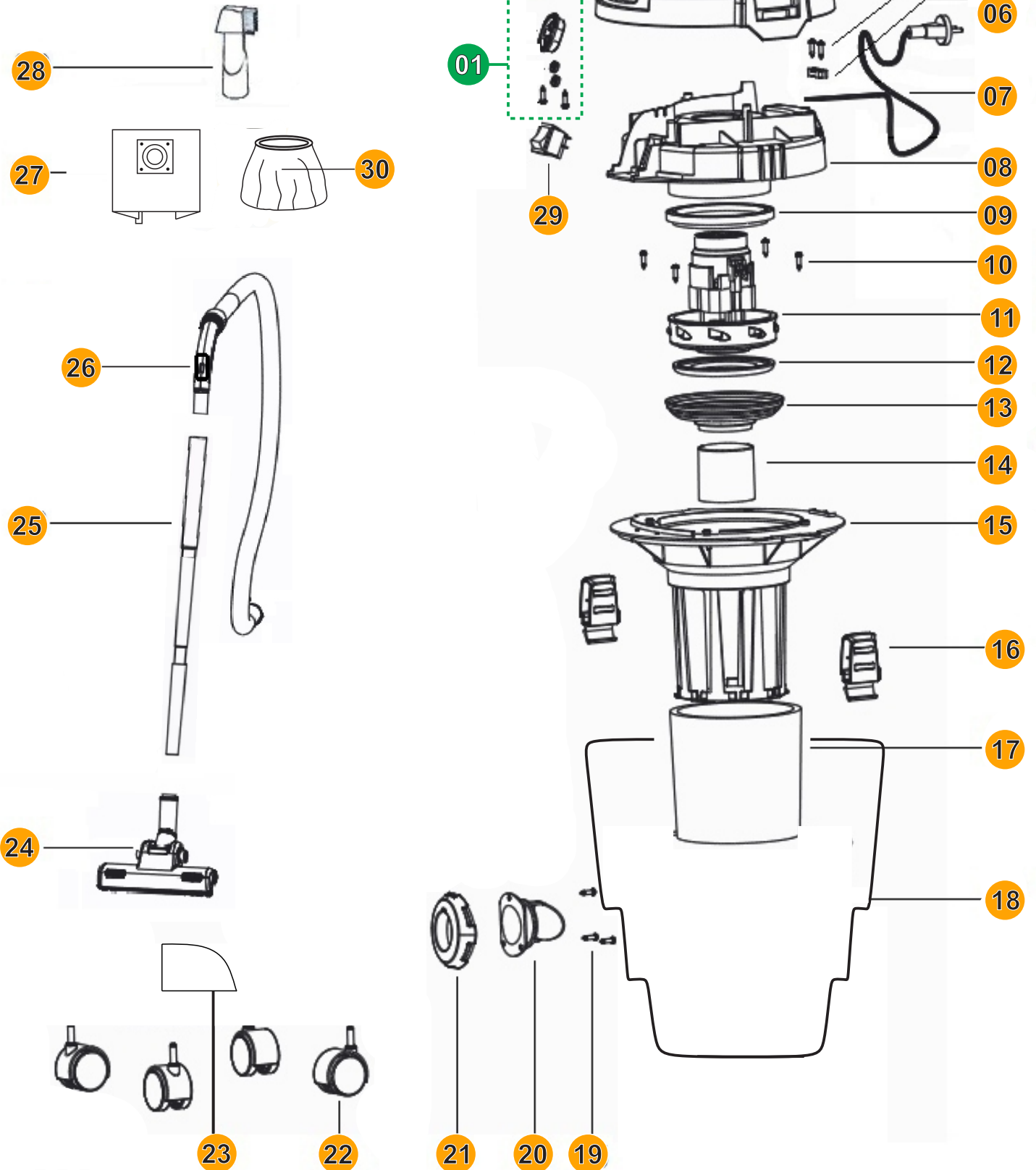

Lista de Peças

POS	CÓDIGO	DESCRIÇÃO	QUANT.	FOTO
1	FW005231	CONJ. BOTÃO INTERRUPTOR	1	
2	-	PARF M4X18	2	-
3	FW005233	ALÇA PLÁSTICA	1	
4	FW005234	CABEÇOTE GTW 12/20L	1	
5	-	PARF PRENSA CABO M4X18	2	-
6	FW005236	PRENSA CABO	1	
7	FW005237	CABO ELÉTRICO 2,5M	1	
8	FW005238	SUORTE SUP. MOTOR	1	
9	FW005239	ANEL VEDAÇÃO SUPERIOR MOTOR	1	
10	-	PARF M3X10	4	-

Lista de Peças

POS	CÓDIGO	DESCRIÇÃO	QUANT.	FOTO
11	FW005241	MOTOR ELÉTRICO 127V	1	
	FW005242	MOTOR ELÉTRICO 220V		
12	FW005243	ANEL VEDAÇÃO INFERIOR	1	
13	FW005244	BASE APOIO MOTOR	1	
14	FW005245	BÓIA	1	
15	FW005246	GAIOLA DA BÓIA	1	
16	FW005247	FECHO	2	
17	FW005248	FILTRO ESPUMA	1	
18	FW005704	RECIPIENTE PLÁSTICO GTW 10	1	
19	-	PARF M3X14	3	-
20	FW005251	BOCAL	1	

Lista de Peças

POS	CÓDIGO	DESCRIÇÃO	QUANT.	FOTO
21	FW005252	CONEXÃO BOCAL	1	
22	FW005253	KIT RODÍZIO	1	
23	FW005592	SUPORE DO RODÍZIO	4	
24	FW005255	BICO MÚLTIPLO GTW INOX 12/ BIOVAC 10/ GTW 10	1	
25	FW005256	EXTENSÃO RETA	3	
26	FW005257	MANGUEIRA 1,5 M	1	
27	FW005258	SACO PARA PÓ DE PANO GTW INOX 12/ BIOVAC 10/ GTW 10	1	
	FW005736	SACO PARA PÓ DE PAPEL GTW INOX 12/ BIOVAC 10/ GTW 10	1	
	FW005870	SACO PARA PÓ DE PAPEL NAC ASPO GTW INOX 12/BIOVAC 10/GTW 10	1	
28	FW005259	BICO CANTO ESCOVA	1	

Lista de Peças

POS	CÓDIGO	DESCRIÇÃO	QUANT.	FOTO
29	20010123	INTERRUPTOR AERO CLEAN	1	
30	FW008889	FILTRO DE PANO PARA PÓ	1	
*	FW008730	CX WAP GTW 10 - PARDA	1	-
*	FW005709	CX WAP GTW 10	1	-
*	FW006036	ETIQ C. BAR WAP GTW 10 127V	1	-
*	FW006035	ETIQ C. BAR WAP GTW 10 220V	1	-
*	FW005710	MANUAL DE INSTR WAP GTW 10	1	-

Diagrama Eléctrico

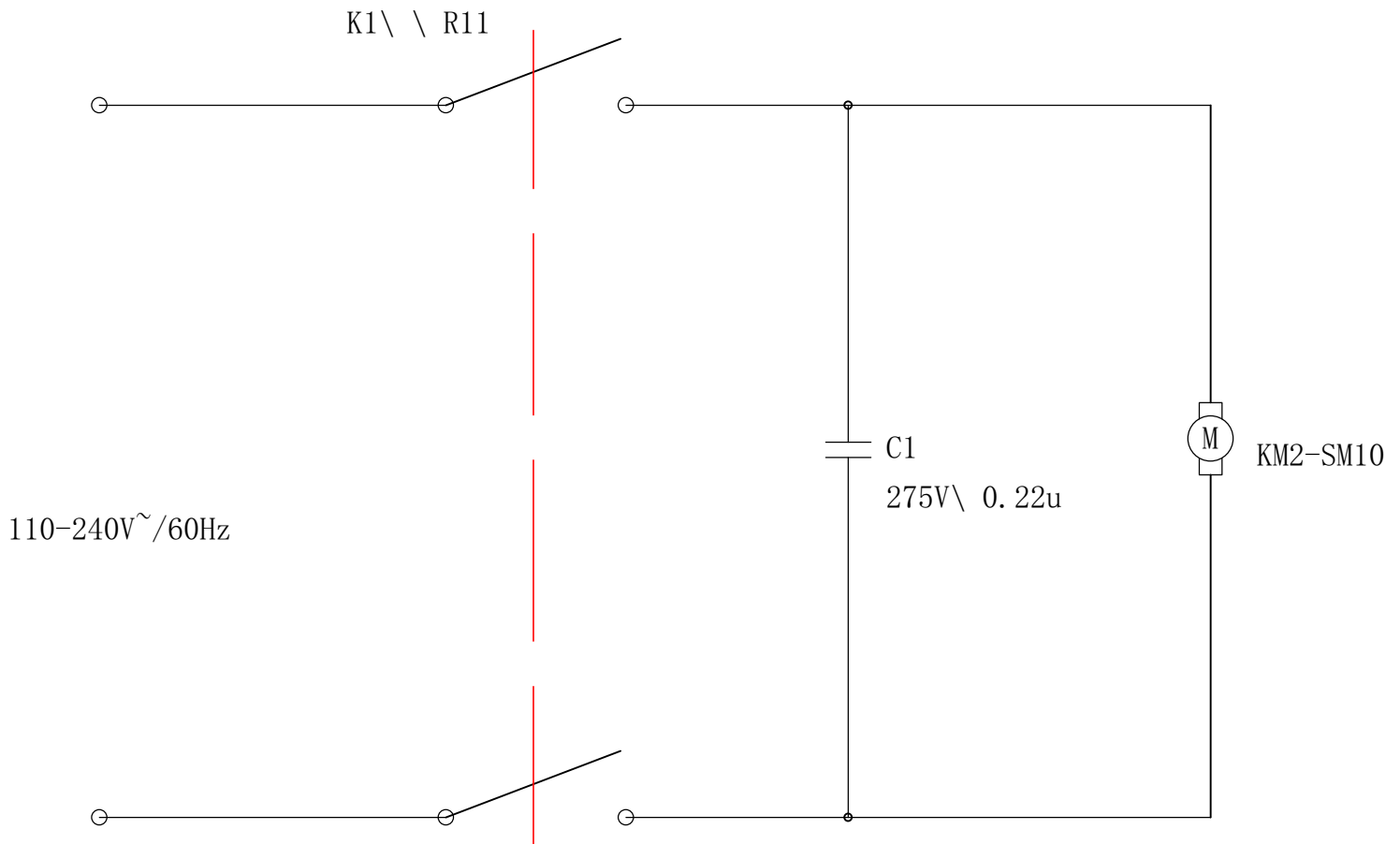

Lista de Revisões

N°	DESCRIÇÃO	DATA
0	Emissão inicial	29/06/2017
1	Revisão geral	30/06/2017
2	Inclusão do código FW005870	02/11/2018
3	Inclusão dos códigos FW005709/FW005710/FW006035/FW006036	09/08/2021
4	INCLUSÃO DO CÓDIGO FW008730	05/08/2022
5	Inclusão de imagens	09/09/2024



Fresnomaq Indústria de Máquinas S/A
Tel.: (41) 3513-9600 - Fax: (41) 3513-9630
Rua Antônio Singer, 200 - São José dos Pinhais, PR, Brasil
www.wap.ind.br - wap@wap.ind.br