

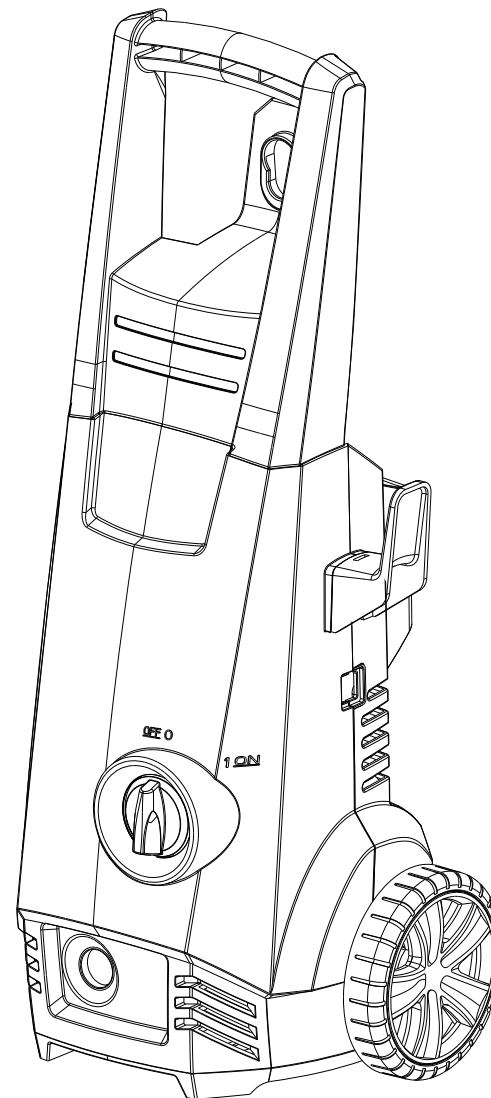

VISTA EXPLODIDA

CONSTRUDECOR 1600psi

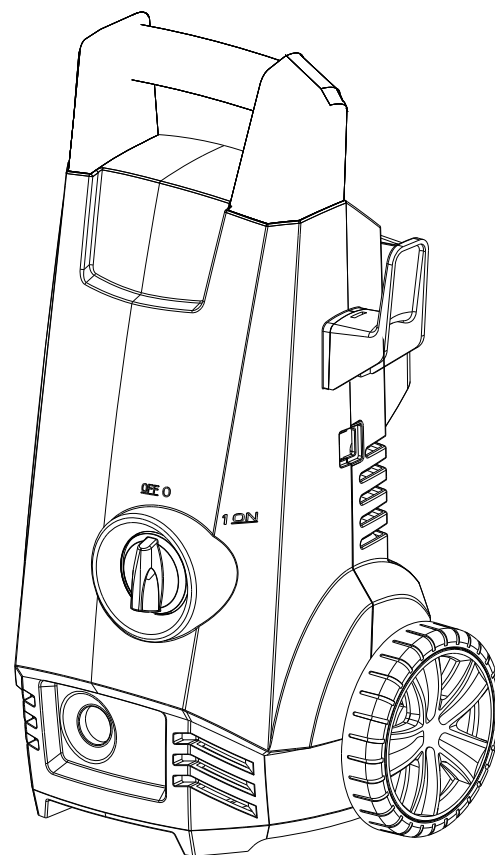

Wap[®]

Marca de Profissional

JANEIRO 2014
Revisão 02

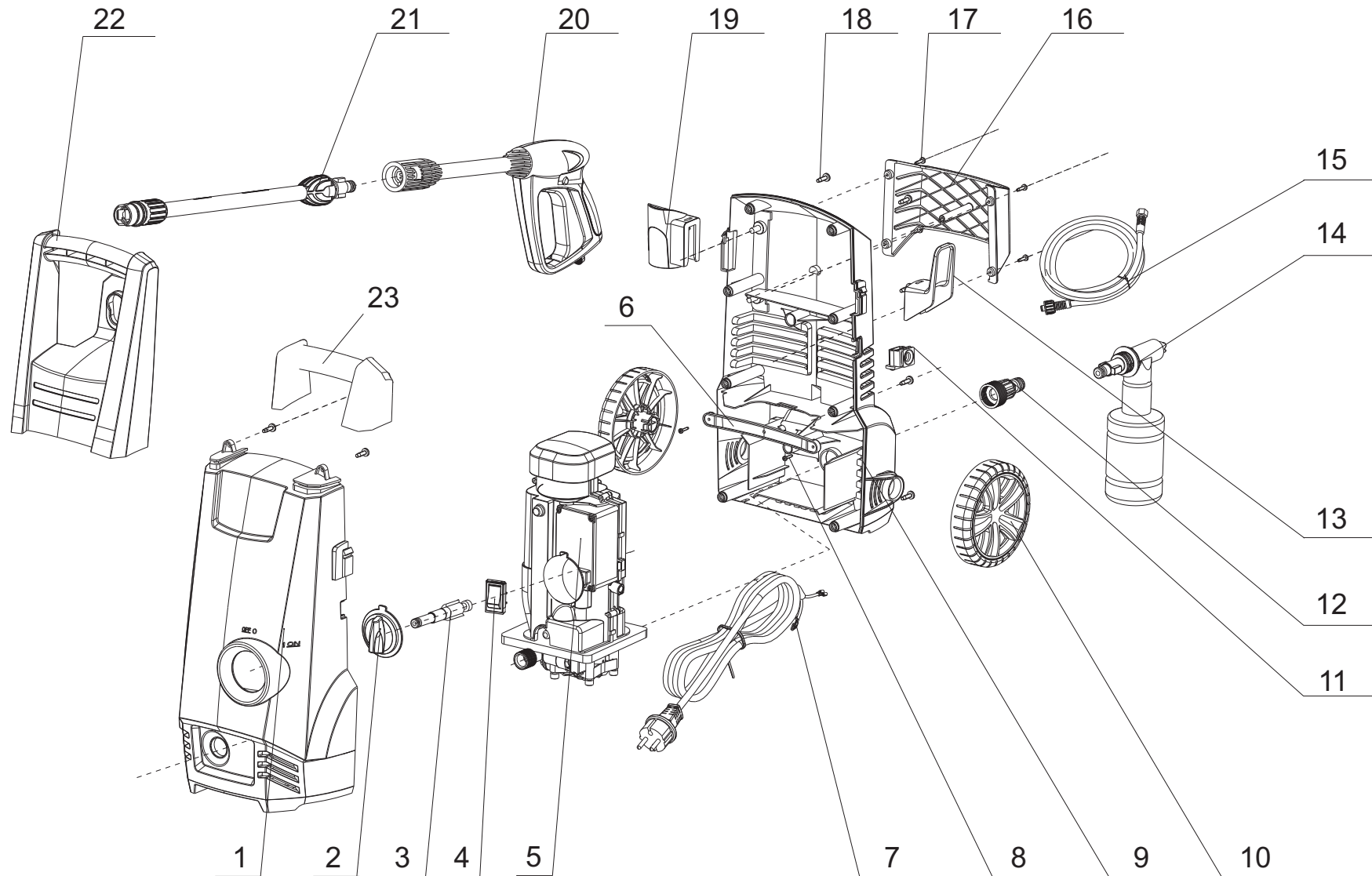

POS.	CÓDIGO	DESCRIÇÃO
1	FW000784	CARENAGEM FRONTAL CONSTRU DECOR
2	FW000506	BOTÃO LIGA/DESLIGA
3	FW000507	ACIONADOR DO INTERRUPTOR
4	FW000508	INTERRUPTOR 12A 250V
5	FW000509	TAMPA CAIXA DE LIGAÇÃO
6	FW000510	CHAPA DE PLASTICO
7	VB70-0060A	CABO ELÉTRICO 2x1,5mm PINO 4,8mm (127V)
7	VB70-0060	CABO ELÉTRICO 2x1,5mm PINO 4mm (220V)
8	FW000511	PARF AA 2,9x13 CP-FC ZN
9	FW000512	CARENAGEM TRAZEIRA
10	FW000513	RODA
11	FW000514	PRENSA CABO
12	FW000515	ENGATE RÁPIDO C/ ESPIGÃO
13	FW000516	SUPORTE DA MANGUEIRA
14	FW000786	RECIPIENTE DE DETERGENTE CONSTRU DECOR
15	20010907	MANGUEIRA AP
16	FW000518	PORTA ACESSÓRIOS
17	50170000	PARF PP 3,5x14 CP-FC ZN
18	70007021	PARF PP 5x16 CP-FC ZN
19	FW000519	SUPORTE DA PISTOLA
20	20010905	PISTOLA
21	FW000520	LANÇA VARIUM
22	FW000521	ALÇA TRANSPORTE LONGA
23	FW000522	ALÇA TRANSPORTE CURTA

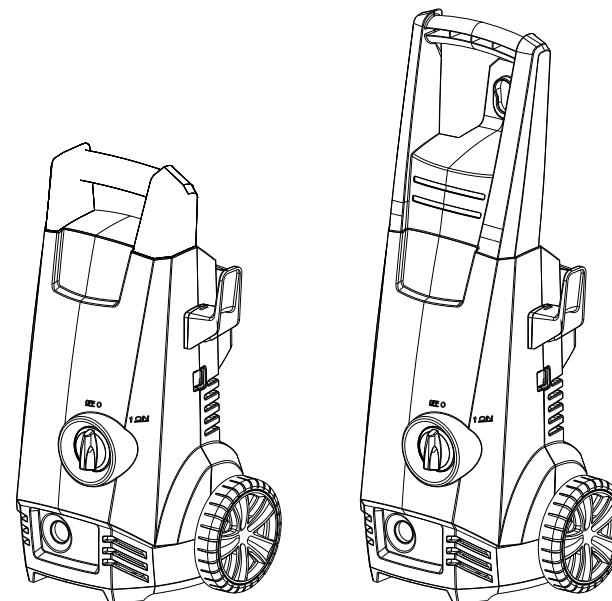

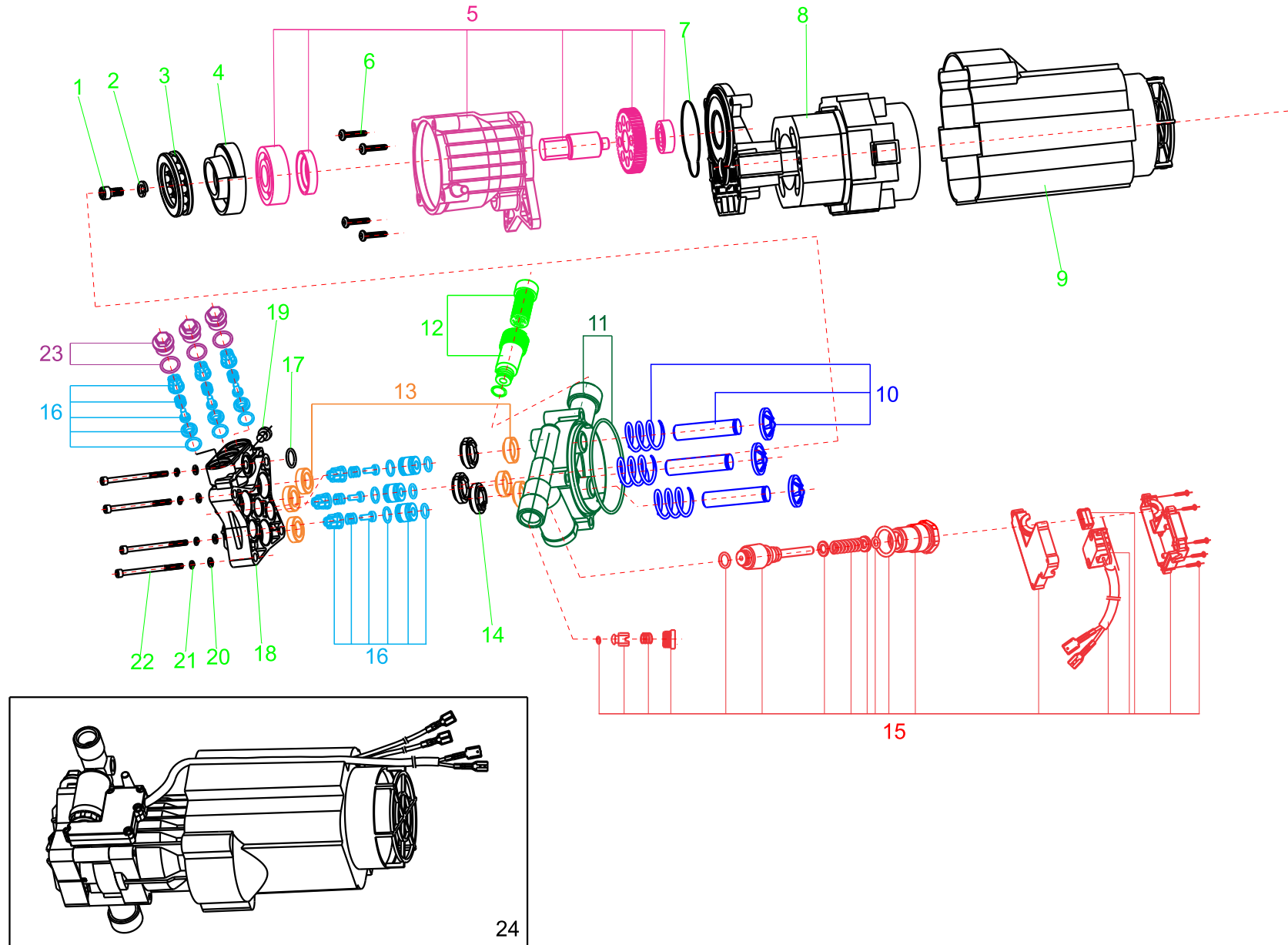

POS.	CÓDIGO	DESCRIÇÃO
1	21471062	PARF ALLEN M8x20 ZN
2	70001008	ARR PRESS 8mm ZN
3	FW000523	ROLAMENTO ESFERA
4	FW000524	CAME
5	FW000542	CONJUNTO CARTER ENGRENAGEM
6	70007030	PARF PP 6x20 CP-FC ZN
7	FW000525	ANEL O'RING MT ÁGATA/C.DECOR/A.MAX
8	FW000526	MOTOR 127V 50/60Hz 1400W
8	FW000527	MOTOR 220V 50/60Hz 1400W
9	FW000528	PROTETOR MOTOR
10	FW000529	KIT PISTÃO
11	FW000530	GUIA PISTÕES
12	FW000531	CONJUNTO ENTRADA DE ÁGUA
13	FW000532	KIT VEDAÇÃO
14	FW000533	ANEL CENTRALIZADOR
15	FW000534	CONJUNTO BY PASS E MICRO SWITCH
16	FW000535	KIT VALVULA SUÇÃO E PRESSÃO
17	15062000	O-RING 6,0x2,0 70 SH 6509
18	FW000536	CABEÇOTE
19	FW000537	PARF M6x8 CP-FC ZN
20	41511000	ARR LISA M6 DIN-125 ZN
21	70001006	ARR PRESS 6mm ZN
22	FW000538	PARF ALLEN M6x50
23	FW000539	CONJUNTO TAMPÃO
24	FW000540	CONJUNTO MOTOBOMBA 127V 50/60Hz 1400W (SOMENTE VENDA)
24	FW000541	CONJUNTO MOTOBOMBA 220V 50/60Hz 1400W (SOMENTE VENDA)

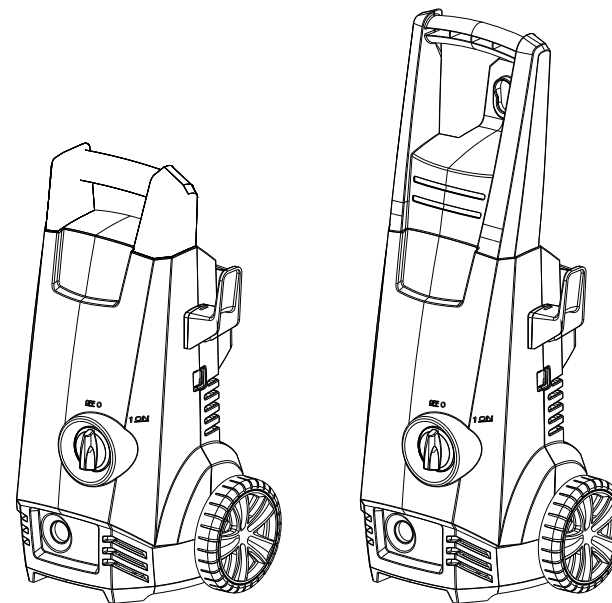



Wap[®]

Marca de Profissional

Fresnomaq Indústria de Máquinas S/A.
Rua Francisco Dal Negro, 3400
83025-320 - São José dos Pinhais - PR - Brasil
Tel: (41) 2102-0300 / Fax: (41) 2102-0334
wap@wap.ind.br www.wap.ind.br